

CS5400 BarCoded YardStick™

Easy measuring for getting started

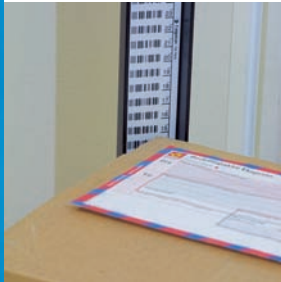

Simple measuring principles

for determining the length, width and height of a rectangular object. The unit has a barcoded measuring strip on each axis. Operators only need to place the object in the corner and scan the barcodes that are clear from the object in each direction. When all three dimensions are read, the volume is determined.



Quick return on investment

also when your goods throughput is relatively low. With the capability of measuring 200 objects per hour, this fast, yet low cost solution, provides you the means to improve your material handling processes for maximum efficiency. The user-friendly and robust design requires very little operator training and maintenance.



Flexible solution

with the possibility of building a system of your choice. The unit can be delivered as a complete data capture solution with dimensioner, scale and barcode reader. The modular design allows for use of existing bar code readers. Scale is optional and there are mounting brackets for several types. You can choose between a metric or imperial version.



Small footprint

with a compact and ergonomic design for optimal reading. The solution takes up nearly no space and can be integrated throughout your operation. The stainless steel measuring surface is solid, but lightweight and can therefore be easily moved between different locations to meet your needs.

CargoAMS	
Height:	27 cm
Left dimension:	20 cm
Right dimension:	34 cm
Last barcode read:	
1Z0195X9021	

Seamless communication

of data between the system and the customer's host. Our application software ensures secure collection of object dimensions, weight and ID. This information can be transferred via file transfer protocol or serial communication to your host computer system. In legal for trade applications, we offer tamper-proof storing of the data.



CS5400 BarCoded YardStick™

Static package solution

Manually measuring the dimensions of objects is time-consuming and error prone. The CS5400 BarCoded YardStick™ automates the process by allowing you the ability to capture this data quickly and reliably and to send this information to your host computer system. This provides you the means to improve your warehouse planning and shipping cost management procedures.

Small goods terminals, parcel drop off centres, post offices, shipping docks and warehouses can now measure objects accurately and more efficiently, at a very reasonable cost. In conjunction with a barcode reader and scale, the CS5400 BarCoded YardStick™ provides you with a complete data capture solution.

Technical data

CS5400 BarCoded YardStick™

Static package solution

Features and benefits

- Ultrasonic technology for easy measuring
- Handheld barcode reader for automatic ID and reading of bar codes for determination of dimensions ¹⁾
- Barcode strips on 3 axis for secure calculation of the dimensions
- Metric or imperial version available for user requirements
- Barcodes for horizontal dimensions are angled so that the operator does not need to tilt the bar code reader when scanning
- Replacement barcoded strips for easy service
- User code 128 barcode standard
- Integrated scale for reliable weighing ²⁾
- Mounting brackets for several scale types
- Stainless steel measuring surface for robust and easy handling and a flat measuring plane
- Check digit to ensure correct reading
- Mounting possibilities for stand alone or as part of conveyor system
- Easy to use PC software and data communication possibilities
- Height stick on left or right side for fitting the operation process
- Merging software for secure collection and linking of dimensions, weight and ID
- Host communication for seamless transfer of data to customer host
- Bar code validation for customizing barcodes to accept or reject
- Alibi memory for tamper-proof storage of data ³⁾
- Graphical colour user-interface and 12" TFT monitor for clear overview
- Easy to connect any component with serial RS232 interface

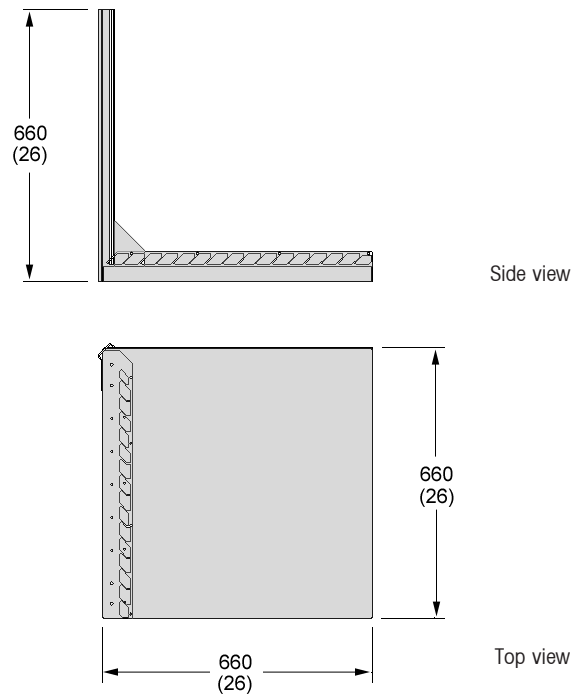

Specifications

Dimension interval	± 1 cm (0.5 in)
Maximum size (LxWxH)	63 x 63 x 61 cm (25 x 25 x 24 in)
Minimum size (LxWxH)	1 x 1 x 1 cm (0.5 x 0.5 x 0.5 in) ⁴⁾
Throughput	Up to 200 parcels/hour ⁵⁾
Shape	Rectangulars
Surface characteristics	Stainless steel
Orientation	Tight into corner
Spacing	Object are placed on the dimensioner one by one
Operational temperature	-10° to 40 °C (14° to 104 °F)
Power	230 V 50 Hz, or 115 V 60 Hz
Bar codes	128 bar code standard
Interface	RS232 and Ethernet (TCP/IP)
I/O ports	VGA, USB, keyboard, binary in, binary out

- ¹⁾ Datalogic wireless handheld scanner recommended
- ²⁾ METTLER TOLEDO IND or PS scale recommended
- ³⁾ Only required for legal for trade applications
- ⁴⁾ In legal for trade applications 5 x 5 x 5 cm (2 x 2 x 2 in)
- ⁵⁾ Depends on site conditions and operator

Main components

Dimensioner	CS5400 plate with 3 axis and bar code strips
Bar code reader	Datalogic wireless handheld scanner ¹⁾
Scale	METTLER TOLEDO IND or PS scale ²⁾
PC	MPS industrial PC with 12" TFT monitor and keyboard
Application software	CSM Basic for capture and transfer of data to host

All hardware and software components are optional and can be purchased separately or as a complete data capture solution.



National approvals
Compliant to health and safety regulations
Internet: <http://www.mt.com>
Worldwide service

Subject to technical changes
© 12/2006 Mettler-Toledo Cargoscan AS
Printed in Norway 790093
CSN MarCom Oslo

www.mt.com/cargoscan

Visit for more information