

Model 3138-N Merge



3138-N Merge

Printer Applicator

Merge

3138-N Merge Printer Applicator Specifications

The NEW Label-Aire® Model 3138-N Merge Printer Applicator prints and applies labels fast and accurately using Label-Aire's proven wipe-on labeling technology.

The Model 3138-N Merge Printer Applicator delivers on its promise of accuracy, reliability, and ease of use. That translates into lower operating costs and increased productivity for your business.

The advanced 3138-N Merge is Label-Aire's latest printer applicator featuring New Generation technology making it the ideal choice for the most demanding applications. The 3138-N Merge utilizes Label-Aire's wipe-on technology for fast, accurate, and versatile labeling. Advanced features include automatic setup with multiple programmable label pages for easy change-overs to labels of different sizes, rate compensation for improved label placement accuracy, and advanced user-configurable I/O connectivity. All these handy features greatly simplify setup and change-overs. The 3138-N Merge is just as tough as it is advanced. Its rugged stainless steel and anodized aluminum construction is corrosion resistant providing long-lasting durability and maintenance-free operation in the most hostile environments.

Like the rest of Label-Aire's printer applicator line, the Model 3138-N Merge is built to meticulous quality standards and designed to withstand the most demanding operation.

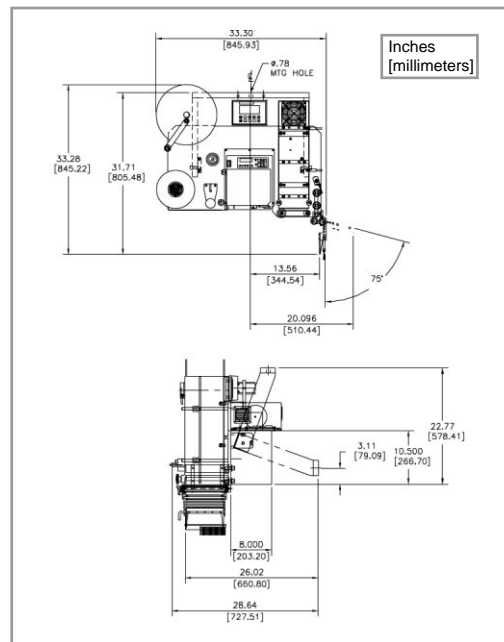

Dimensions:

Height: 33.3" (846 mm)
 Length: 33.3" (846 mm)
 Width: 28.6" (726 mm)

Weight:

165 lbs. (75 kg)

Standard Label Dimensions:

Label Width: Up to 7.2" (183 mm)
 Label Length: Up to 7" (178 mm)
 (Printer dependent)

Dispense Speed:

Up to 25" (635 mm) per second when label storage box is full (depending on printer and label size)
 Up to 16" (406 mm) per second when label storage box is low (depending on printer and label size)

Label Placement Accuracy:

Up to +/- 1/32" (0.8 mm)

Electrical:

115 Volts AC 60 Hz 3 Amps.
 220 Volts AC 50 Hz optional

Options:

Datamax, Sato, and Zebra O.E.M. print engines

Consult factory for additional options.

3138-N Merge Advanced Features	
Automatic setup	Includes multiple programmable label pages for easy change-overs to different label sizes.
Wipe-on technology	Can be configured for wrap labeling. This is accomplished by utilizing a label loop box for the storage of pre-printed labels.
Automatic Speed Following (ASF)	Provides accurately applied labels even through changes in product speed.
Digital display	Remote operator control capability.
Flash memory	Allows easy download of system software updates.
Advanced I/O	User-configurable for system output signals.



Headquarters

550 Burning Tree Road
 Fullerton, CA 92833 USA

o 714.441.0700
 f 714.526.0300
 e info@label-aire.com
 w www.label-aire.com

Europe

Sjællandsvej 27A
 DK-9500 Hobro, Denmark

o +45 9657 0063
 f +45 9657 0064
 e info@label-aire-as.com
 w www.label-aire-as.com

Distributed by:

