



MS2422
Subcompact scanner only

MS2400 Stratos®

Metrologic's MS2400 Stratos premium five-sided, bioptic scanner/scale increases productivity in demanding, high-volume seated and small checkout environments. Patented independent scanning planes and modular design promote easy set up, lower maintenance costs and ensure continuous operation.

From Metrologic comes the MS2400 Stratos, the newest member of the company's premier line of 360°-bioptic scanners.

The MS2400 Stratos features a faster microprocessor, enhanced signal processing, enriched decoding software and an optimized vertical scan pattern.

To help retailers boost checkout productivity, Metrologic redesigned the Stratos **SPHERE** scanning architecture. Stratos **SPHERE** powers the scanner's high first-pass read rate and gives operators using a rapid scanning motion the ability

to process a product in a single pass regardless of bar code type or orientation.

Unlike other bioptic devices, MS2400 Stratos is the only one to offer pre-aligned optical scanning modules, and independent scanning planes which enable the scanner to maximize uptime and maintain productivity.

The MS2400 Stratos maximizes return on investment with two analytical tools for tracking, managing and improving checkout productivity and efficiency. Stratos **STATS** provides real-time visibility into key data points directly impacting checkout productivity. Stratos **SCHOOL** captures information necessary to improve operator scanning techniques and safety.

www.metrologic.com/MS2400

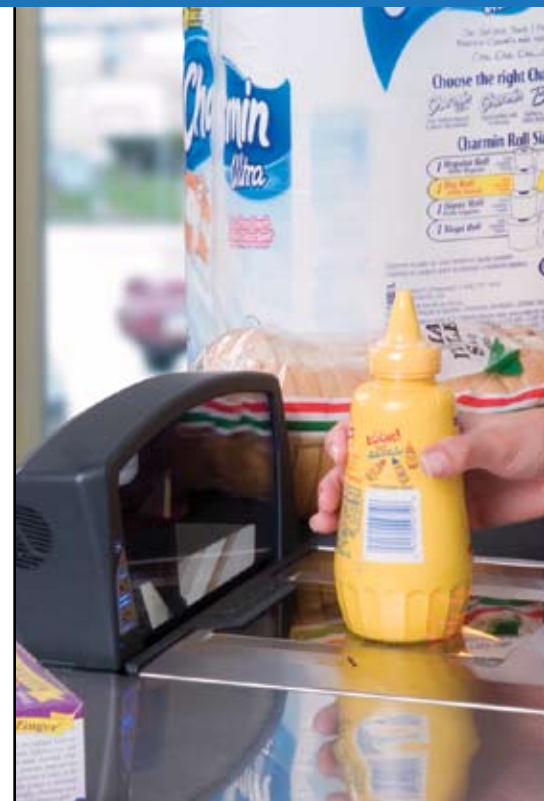

Features

- Stratos **SPHERE**™ - advanced scanning architecture
- Stratos **SYNC**™ - independent scanning planes
- Stratos **SWAP**™ - pre-aligned optical scanning modules
- Stratos **STATS**™ - productivity analytical software
- Stratos **SCHOOL**™ - operator training software

Benefits

- Increases rapid pass-through scanning productivity with high first-pass read rate
- Maintains productivity and uptime via independent scanning planes
- Minimizes downtime and lowers the cost of service via modular optical scan engines
- Provides data critical to maintaining checkout productivity
- Improves productivity and promotes safer scanning techniques

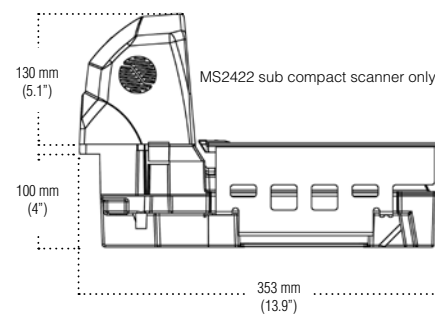
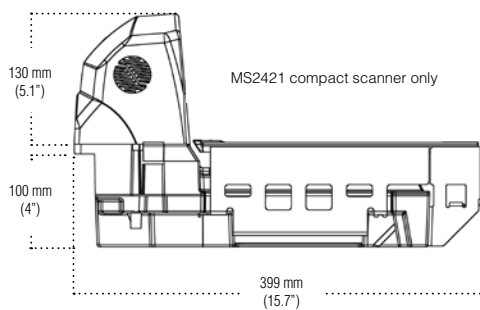
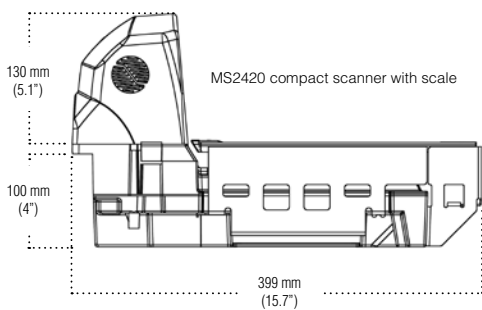

OPERATIONAL

Light Source	Visible laser diode 650 nm ± 10 nm
Laser Power	1mW/1mW
Decode Capability	All standard 1D bar codes, GS1 DataBar™ and GS1 DataBar™ Expanded
System Interfaces	RS232, Aux. RS232, USB, IBM468x/469x
Number Characters Read	Up to 80 data characters
Beeper Operation	7 tones or no beep
Indicators (LED)	Blue = power on, good scan; 7 - segment display = diagnostic indicator

MECHANICAL

Height (above counter)	130 mm (5.1")
Depth	100 mm (4")
Width	292 mm (11.5")
Length	MS2420 (compact scanner with scale) 399 mm (15.7") MS2421 (compact scanner only) 399 mm (15.7") MS2422 (sub compact scanner only) 353 mm (13.9")
Weight	MS2420 (compact scanner with scale) 9.97 kg (22 lbs) MS2421 (compact scanner only) 7.20 kg (16 lbs) MS2422 (sub compact scanner only) 6.80 kg (15 lbs)

ELECTRICAL

Input Voltage	5.2 V @ 2.5 Amps / 12 V @ 0.8 Amp
Power	13 W (when scanning); 3.25 W (standby)
Operating Current	1.7 A (5.2 V) / 250 mA (12 V)
DC Transformers	Class1; 5.2 VDC @ 2.5 A; 12 VDC @ 0.8 A
EMC	FCC, ICES-003 & EN55022 Class B
ESD	8 kV direct; 15 kV air discharge

ENVIRONMENTAL

Operating Temperature	0°C to 40°C (32°F to 104°F)
Storage Temperature	-40°C to 60°C (-40°F to 140°F)
Humidity	5% to 95% relative humidity, non-condensing
Light Levels	4842 Lux (450 foot-candles)

Product Colors Available



MS2400 is available in a variety of other colors with minimum quantity purchase.

SCAN PERFORMANCE

Depth of Scan Field - (horizontal)	0 mm - 100 mm (0"-4") for 0.33 mm (13 mil) bar code
Depth of Scan Field - (vertical)	0 mm - 216 mm (0"-8.5") for 0.33 mm (13 mil) bar code
Scan Speed	5400 scan lines per second
Number of Scan Lines	54 (38/16)
Scan Zone	360°
Minimum Bar Width	0.127 mm (5 mil)
Print Contrast	35% minimum reflectance difference
Roll, Pitch, Yaw	360°, 60°, 60°

SCALE SPECIFICATIONS

Capacity	15 kg (30 lb)
Minimum Legal Weight	0.005 kg (0.01 lb)
Maximum Static Weight	68 kg (150 lb)
Adjustments Required	Field calibration if necessary
Applications	Weight-only and price computing
Scale Partners	Avery Weigh-Tronix®, Bizerba®, Dibal®, Digi®, and Mettler Toledo®

All Models

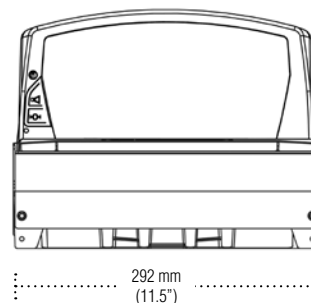

Specifications subject to change without notice. Printed U.S.A., Copyright January 2008 Metrologic, all rights reserved.



Metrologic Instruments, Inc. | Worldwide Headquarters
90 Coles Road | Blackwood, NJ 08012-4683 | info@metrologic.com
Telephone 856-228-8100 | Fax 856-228-6673 | www.metrologic.com

Asian Headquarters Tel. 65.6842.7155 info@sg.metrologic.com
European Headquarters Tel. 49.89.89019.0 info@eu.metrologic.com
The Americas Headquarters Tel. 1.800.ID.METRO info@us.metrologic.com



DS2400