



MS9590 VoyagerGS™

Metrologic's MS9590 VoyagerGS™ hand-held single-line laser scanner increases productivity by offering an aggressive solution for scanning all standard 1D bar codes.

As the newest addition to the industry-leading Voyager® series, the MS9590 VoyagerGS features a new ergonomic design that maximizes comfort and reduces fatigue for customers desiring a trigger-activated, hand-held laser scanner. This new form factor makes the scanner ideal for a variety of applications, including retail point-of-sale, office automation and healthcare settings.

Optional EAS integration allows retailers to save time and money by simultaneously deactivating EAS security tags and decoding bar codes.

The VoyagerGS ensures speed and accuracy by combining patented automatic infrared activation technology with an enhanced depth-of-field. This scanner also includes Metrologic's

patented CodeGate® technology which easily completes data transmission with a single trigger pull.

The MS9590 can be configured at no cost by using either the MetroSelect® Single-Line Configuration Guide or MetroSet®2 software via a RS232 or USB interface. The MS9590 also has the ability to format bar code data to meet the specific requirements of host systems.

For presentation scanning, Metrologic offers a flexible stand with automatic in-stand detection technology.



www.metrologic.com/MS9590

Features

- Ergonomic Design
- 100 Scans Per Second
- Durable Construction
- Automatic In-Stand Detection
- Optional EAS Integration

Benefits

- Fits comfortably into a wide range of hand sizes
- Improves scan aggressiveness with increased scanning speed
- Reduces downtime and service costs
- Allows seamless transition from hand-held to presentation mode scanning
- Increases efficiency by simultaneously deactivating EAS tags and decoding bar codes

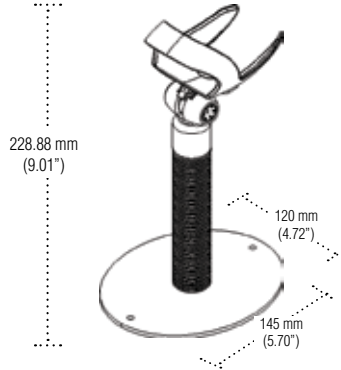
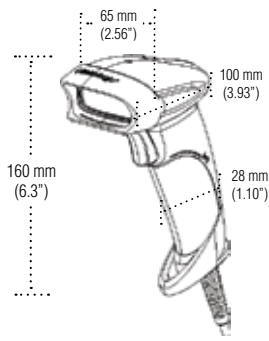

OPERATIONAL

Light Source	650 nm ± 10 nm VLD
Laser Power	Less than 1 mW (peak)
Decode Capability	Autodiscriminates all standard 1D bar codes; for others call a Metrologic service representative
System Interfaces	RS232, USB, Keyboard Wedge, and 46xx RS485
Number Characters Read	Up to 80 data characters
Beeper Operation	7 tones or no beep
Indicators (LED)	Blue = unit powered, ready to scan; White = good read; Yellow Steady = CodeGate is inactive

MECHANICAL

Height	160 mm (6.3")
Depth	100 mm (3.93")
Width	Handle: 28 mm (1.10"); Head: 65 mm (2.56")
Weight	150 g

ELECTRICAL

Input Voltage	5 VDC ± 0.25 V
Power	Operating: 650 mW; Standby: 375 mW (typical)
Current	Operating: 130 mA @ 5VDC; Standby: 75mA @5VDC (typical)
DC Transformers	Class II; 5.2V @ 1 A
Laser Class	Class 1; IEC60825-1:1993/A1:1997+A2:2001 Class 1; EN60825-1:1994+A11:2002+A2:2001
EMC	FCC Class B

ENVIRONMENTAL

Operating Temperature	0°C to 40°C (32°F to 104°F)
Storage Temperature	-40°C to 60°C (-40°F to 140°F)
Humidity	5% to 95% relative humidity, non-condensing
Light Levels	Up to 4842 Lux (450 foot candles)
Shock	Designed to withstand 1.5 m (5') drops

SCAN PERFORMANCE

Depth of Scan Field	0 mm - 305 mm (0" - 12") for 0.330 mm (13 mil) bar codes @ default
Width of Scan Field	50 mm (2") @ face; 300 mm (11.8") @ 305 mm (12")
Scan Pattern	Single scan line
Scan Speed	100 scan lines per second
Minimum Element Width	5 mil (0.127 mm)
Print Contrast	35% minimum reflectance difference

Scan Area

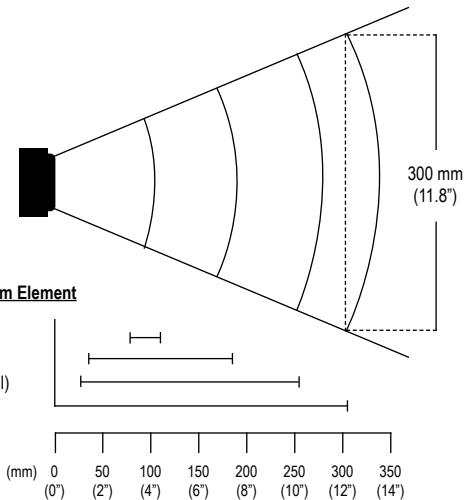

Product Colors Available



MS9590 is available in a variety of other colors with minimum quantity purchase.



Metrologic Instruments, Inc. | Worldwide Headquarters
90 Coles Road | Blackwood, NJ 08012-4683 | info@metrologic.com
Telephone 856-228-8100 | Fax 856-228-6673 | www.metrologic.com

Asian Headquarters Tel. 65.6842.7155 info@sg.metrologic.com
European Headquarters Tel. 49.89.89019.0 info@eu.metrologic.com
The Americas Headquarters Tel. 1.800.ID.METRO info@us.metrologic.com



Specifications subject to change without notice. Printed U.S.A., Copyright January 2008 Metrologic, all rights reserved.



DS9590